



Experiment 112

RFI Hunt

This month's story begins with a *clank* — a rather loud sound emanating from somewhere inside our gas cooking stove. I'd just put up a 105 foot dipole about 30 feet above the kitchen. Operating on 20 and 15 meters was no problem but when I dropped to 30 or 40 meters — *clank*. The oven door latch solenoid was activating whenever a dot or dash was sent, holding for a few seconds after the RF stopped and — *clank* releasing, only to — *clank* activate again on the next transmission. Ellen is tolerant but not so tolerant that I could ignore it, and so the story begins.

General Approach to RFI

Let's back up a little bit. Solving RFI problems requires a somewhat organized approach — without it you'll chase your tail forever or until you give up and go off the air entirely. We can start by dividing RFI into two categories: RFI *caused* by your ham radio equipment and RFI *to* your ham radio equipment. This was clearly in the former category.

In the cases for which your transmissions are causing RFI, there are a series of cases to evaluate. First, is the *victim* device experiencing the RFI designed to receive a radio signal as part of its normal operation — such as a TV or cordless phone? If so, the first thing you must do — even according to the FCC rules — is to determine or ensure that your station is not generating a spurious signal on the frequencies intended to be received by the victim. For example, in the case of RFI to a weather radio, your station should not be generating any signals on the frequencies of the weather alert transmissions. If it is, go no further and either fix the transmitter or add the necessary transmit filters.

Assuming that the device is a receiver of some sort and your transmissions are *clean* (free of spurious emissions), determine whether or not it is simply the strength of your signal causing the problem. For example, a commercial broadcast FM receiver's front end circuitry could be overwhelmed by a strong 2 meter FM signal from your nearby mobile rig. This is called *fundamental overload* and is a symptom of a receiver being overwhelmed by a strong signal via its normal receive path. The usual fix here is a

filter in the receive signal path to the receiver (such as in the antenna feed line). Obviously, the stove was not designed to receive RF signals so it was on to the final case.

This final case is the most common form of RFI from ham transmissions now that most TV reception is not via over-the-air analog signals. In this case, the signal from your station is being picked up as *common-mode current* by external cables or wires attached to the victim device. (See Hands-On Radio experiment #91, "The Common-Mode Choke," for a discussion of common and differential mode signals.)¹ Those currents are then conducted into the device where they disturb its normal operation in some way. If you can block those signals from getting into the device — usually by using some kind of common-mode choke or shielding — you can solve the problem. That's what I expected would solve my problem with the stove.

There is one additional frequent RFI case — *direct pickup* — in which the wiring

inside the device picks up the signal without any external cables or wires. This is often the case for battery powered devices and can be very difficult to solve. Guess which mine turned out to be?

Let's Get Cooking

The stove is made of heavy sheet metal and, as with every other appliance these days, has a microprocessor that controls its functions. The only external wiring is the ac line cord. As Figure 1 shows, the stove sits directly under the antenna. Testing showed that the RFI only occurred at power levels greater than 25 W and only on the bands at and below 10 MHz. With the antenna so close, the stove was clearly in enough V/m of field strength to cause interference.

My first — and only — candidate for picking up common-mode signals was the ac line cord to a socket directly in back of the stove. Opening up my shack notebook and starting a troubleshooting log for recording each step, I grabbed some ferrite split cores (the common variety available at RadioShack) and snapped them on the ac power line where it entered the back of the stove through a hole in the sheet metal. [While the split core type of ferrite bead is

¹All previous Hands-On Radio experiments are available to ARRL members at www.arrl.org/hands-on-radio.

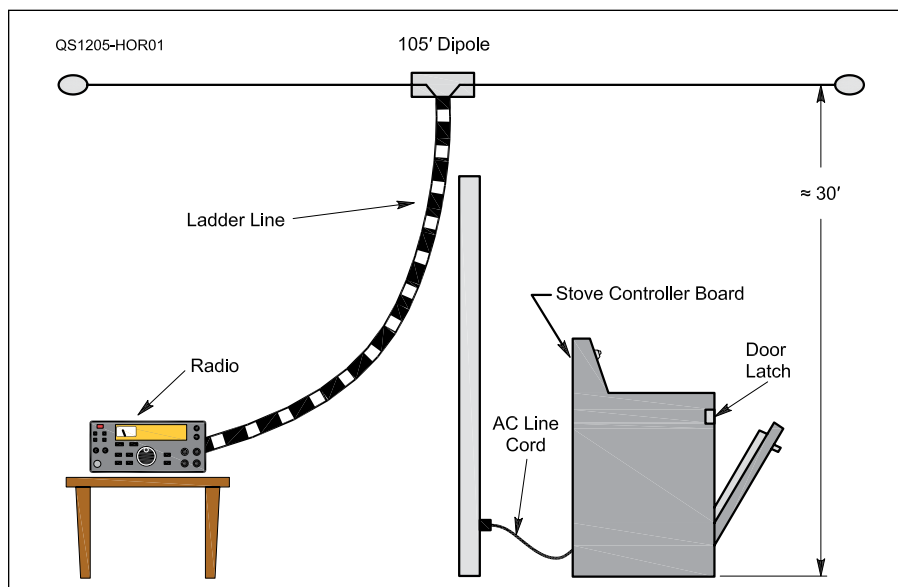

Figure 1 — The gas stove experiencing the RFI was directly underneath the HF dipole less than 30 feet above it. Even though the stove was made of sheet metal and the wiring completely enclosed, there was still enough RF picked up by the latch solenoid wiring to cause a problem.

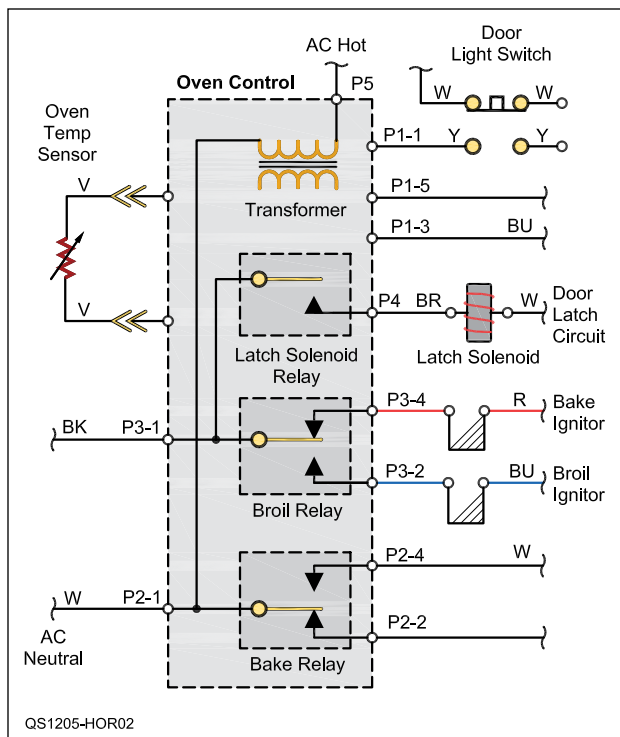

Figure 2 — This excerpt from the stove service manual shows the connection terminal numbering for each input and output to the controller board. This helps identify which terminals to bypass and what voltages may be present.

handy, it generally is more appropriate to suppression of VHF signals. HF RFI generally requires multiple turns around a toroidal core or multiple split cores of appropriate mix. — *Ed.*]

At the lowest power at which the RFI occurred, the cores had no effect on the RFI. I have since obtained cores made of #31 material, optimized for RFI suppression below 10 MHz. See K9YC's online tutorial about RFI and ferrite, the RF Interference chapter of *The ARRL Handbook* or *The ARRL RFI Book*.^{2,4}

The next step was to apply sterner filtering. I purchased a Delta 10DEEG3B ac filter line with a 10 A rating,⁵ attached short

²J. Brown, K9YC, "A Ham's Guide to RFI, Ferrites, Baluns, and Audio Interfacing," audiosystemsgroup.com/RFI-Ham.pdf.

³*The ARRL Handbook for Radio Communications*, 2012 Edition. Available from your ARRL dealer or the ARRL Bookstore, ARRL order no. 6672 (Hardcover 6634). Telephone 860-594-0355, or toll-free in the US 888-277-5289; www.arrl.org/shop; pubsales@arrl.org.

⁴*The ARRL RFI Book*. Available from your ARRL dealer or the ARRL Bookstore, ARRL order no. 6834. Telephone 860-594-0355, or toll-free in the US 888-277-5289; www.arrl.org/shop; pubsales@arrl.org.

⁵Available from Digi-Key (www.digikey.com), part number 603-1135-ND.

pigtails with a plug and receptacle (a metal junction box could also be used), and inserted the filter in the line. Again, no effect on the RFI, even with both the ferrite cores and the line filter. I was going to have to open up the patient.

Finding Resources

The owner's manual for the stove was available but it didn't provide a schematic nor was there a schematic on the inside of the stove's rear cover. By entering the stove's model number (Whirlpool SF385PEE) into an Internet search engine I was able to locate a service manual with the internal wiring diagram showing the wiring for the sensors, power and switches, summarized by Figure 2. I was getting warmer, so to speak.

Safety Check

Before we go any further, it's important to remember some basic safety guidelines. When dealing with an ac line powered appliance, any component that you attach to the ac line *must* be rated for ac line use. Capacitors should be rated for at least 600 V ac, and both capacitors and inductors should use flame retardant insulating materials. This is not the place for components intended for use in low voltage electronics. If you insert any components in series with the ac line, be sure the connections are well insulated with sleeve or heat-shrink tubing. Use cable clamps or small enclosures so that the components and connections can't touch the body of the appliance and aren't subjected to vibration. Appliances often have elevated internal temperatures (particularly stoves) so the components and materials must be adequately rated for high temperature use, as well. And never work on energized equipment.

I'm Going In!

The control board was covered by a single piece of sheet metal and mounted behind the display panel at the top of the range. Along with the hot and neutral ac line wires (safety ground was connected where the line cord entered the stove) there was a bundle of individual wires connected to the control board that carried sensor, switch and control signals. With the external ac filter and cores

still on the external line cord, I added two more cores to the ac line and control bundle — no effect on the RFI. Note that I left all of the attempted fixes in place while I continued to work since the fix can be cumulative — there might not be a "magic bullet" that solves the problem by itself.

The next step was to bypass individual connections to the controller board using capacitors. I'd purchased some line rated 0.0068 µF capacitors and connected one from the hot and neutral to a nearby chassis sheet metal screw. This had the effect of raising the power level required to trigger the solenoid, so I was on the right track. I then added a bypass capacitor across each switch input or control output, one at a time. Bypassing the door latch control output eliminated the clank at all power levels and bands (I can run up to 100 W). Bypassing the other inputs or outputs had no effect.

To verify I'd really found and fixed the problem, it was important to remove the bypass capacitors to see if the problem came back. It turned out that I needed bypass capacitors both on the ac line inputs and across the door latch control output — either alone didn't solve the problem completely. (That there is more than one path for the RF to cause a problem is fairly common.) I also verified that removing the ferrite cores and the ac line filter had no effect so the external components were removed. I left the core on the ac line inside the stove for good measure as shown in Figure 3 in the *QST* Digital Edition and the *QST-in-Depth* website.⁶ In retrospect, the door latch solenoid has the longest wiring run in the stove except for the ac line cord so it was logical to be the weak link.

All this was duly noted in my shack notebook — you *do* keep a shack notebook, don't you? I also put this information out where other Internet search engines could find it by sending an e-mail to the RFI Reflector containing the specifics of the symptom, the affected device, and the solution (available at lists.contesting.com/_rfi/2010-12/msg00044.html). Posting this wouldn't be a bad idea, if you are able to thoroughly solve a similar problem at your location.

Summary

The point of this RFI travelogue is not to teach you how to get rid of RFI in a specific type of gas stove. The description of the journey is its own reward in that it is an example of how to whittle the problem down one step at a time and then solve it in an orderly manner. A deliberate, documented approach may seem like plodding overkill but in my experience, this type of tortoise beats the rabbit more often than not!

⁶www.arrl.org/qst-in-depth.

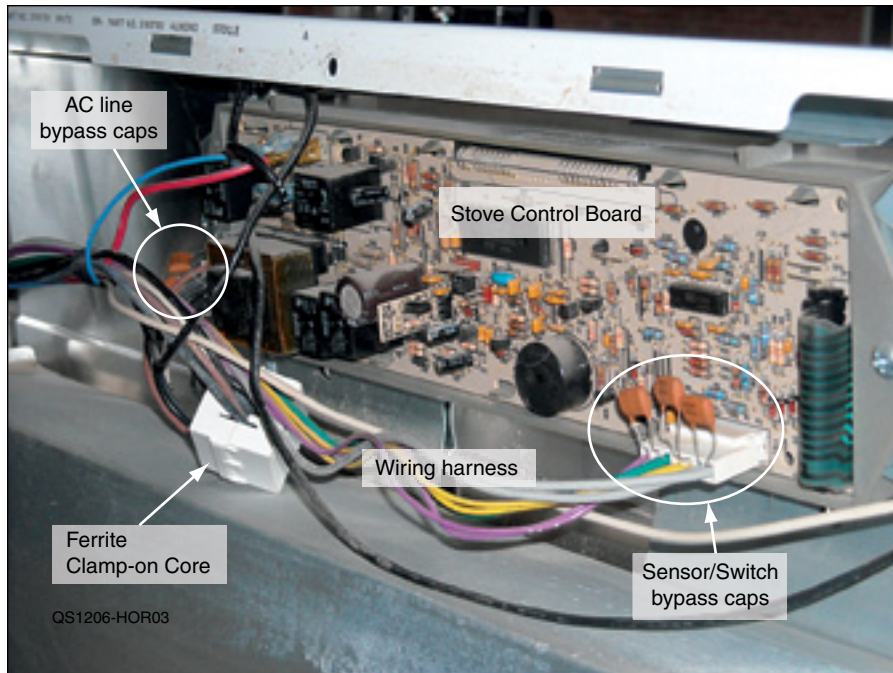

Figure 3 — The controller board with bypass capacitors and a ferrite clamp-on core installed after testing was completed. The controller board is covered with a sheet metal shield in normal operation.